



Master (or Bachelor) Project at Center for Quantum Devices

Multi-qubit operations using spins in GaAs

Electron spins in gallium arsenide (GaAs) heterostructures are an attractive platform to study quantum systems consisting of more than one or two qubits. Our spin qubit team is looking for students interested in studying electron spins in these quantum dots to study fundamental spin physics and electron interactions.

An example of a recent device comprises four double quantum dots (pairs of small circles in image below), each operated as a singlet-triplet spin qubit. The qubits are coupled together into a four-qubit cluster via a multielectron dot (long oval in image), which serves as a coherent coupler.

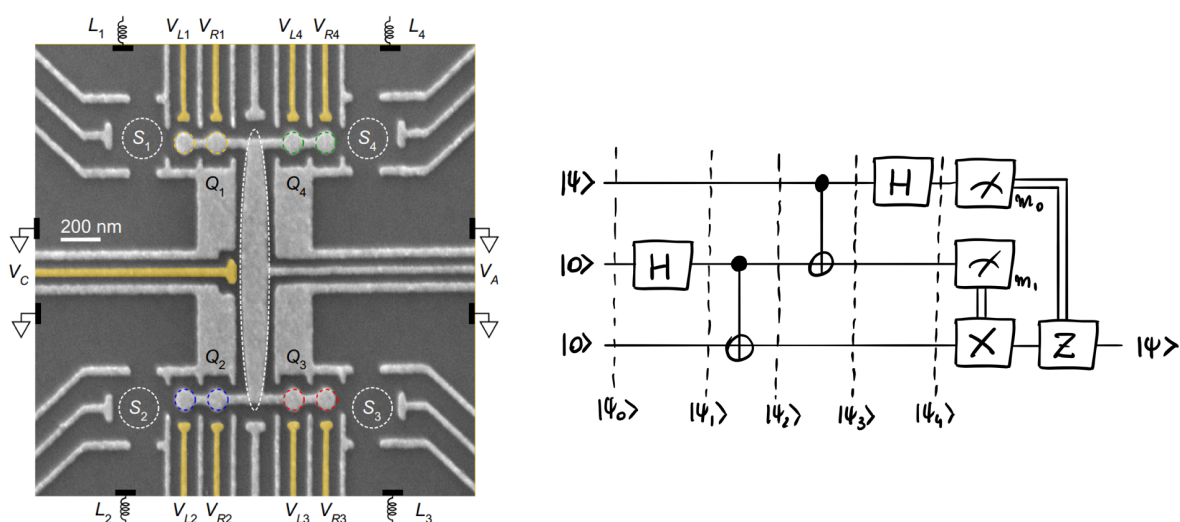

Small spin-qubit processor implemented in GaAs. Ref: F. Fedele et al., PRX Quantum 2, 040306 (2021)

By cooling this device to a temperature close to the absolute zero (20 mK) and applying high-frequency pulses (MHz to GHz), we are able to isolate single electrons in these quantum dots, control and read out their spin state with high fidelity and investigate their intricate spin dynamics. The possibility to couple more than two qubits opens up exciting possibilities, but there are also challenges to be solved. Possible projects addressing some of these challenges include:

- The world's first unconditional quantum teleportation of spin states across a chip.
- Simultaneous estimation of the nuclear fields at all four qubits locations via a multiplexed system based on high-frequency electronics.
- The development of automatic tuning procedures and the implementation of cross compensation techniques in the control software.

If you are interested in these or other projects of the spin qubit team, please contact **Ferdinand Kuemmeth** (kuemmeth@nbi.dk) or **Anasua Chatterjee** (anasua.chatterjee@nbi.ku.dk).



See all QDev student projects here: